

## Warrick® TA-731XX Monitoring Panel Installation and Operation Bulletin

This bulletin should be used by experienced personnel as a guide to the installation of the TA-731 Series Remote Alarm Panels. Selection or installation of equipment should always be accompanied by competent technical assistance. We encourage you to contact the Gems Sensors Inc. or our local representative if further information is required.

### Important

**Before installing and wiring the unit, read these instructions thoroughly.**

**\*\*\* Warning:** To prevent ignition of flammable or combustible atmospheres, disconnect power before servicing.

When installed according to these instructions, this device provides an intrinsically safe output for interface into Class I, II and III, Division 1, Groups A thru G hazardous locations. Electrical equipment connected to associated apparatus should not exceed maximum voltage marked on product.

### Location

The panel must be situated in a non-hazardous area where an explosive atmosphere will not exist at anytime.

### **Specifications**

<b>Supply Voltage</b>	120 VAC +10% -15%. 6.6 VA max
<b>Sensor Voltage</b>	12 VDC, .248 milli-amp current
<b>Indicators</b>	Red, green and yellow solid state LED's
<b>Enclosure</b>	weather tight polycarbonate (6.25h X 3.25w X3.5d)
<b>Terminals</b>	Size 6 pan head screws with captivated wire clamping plate
<b>Temperature</b>	-22°F to +150°F Ambient
<b>Sensitivity</b>	0-26K ohm maximum specific resistance
<b>Auxiliary Contact</b>	SPDT 10A@ 120, 240 VAC, 10A@ 30 VDC, Resistive, 1/3 H.P. @ 120, 240 VAC
<b>Listing</b>	UL Listed, Process Control Equipment Associated Apparatus with Intrinsically Safe Output (913)
<b>Conduit Connection</b>	Sensor, 3/4" NPT, PVC, Power, 1/2" NPT, Metal

### Intrinsically Safe Wiring

1. Terminal strip capable of handling 12-22 gauge stranded wire 14-22 gage solid wire.
2. Intrinsically safe wiring must be kept separate from non-intrinsically safe wiring.
3. Wire the sensor(s) to the TA-731XX as shown in in the wiring diagram on the reverse side. (Diagram D-2)
4. An approved seal should be used at the point where the intrinsically safe control circuit wiring enters the hazardous area.

### Notes

1. All intrinsically safe wiring must be installed in accordance with article 504 of the National Electrical Code, publication ANSI/NFPA 70.
2. **Grounding:** To maintain intrinsic safety, the terminal marked "GND" on the AC supply terminal should be connected to the earth ground buss of the AC power supply feeder. Metal conduit must be used to provide a redundant system ground. The resistance between the system ground terminals (at the control) and the earth ground buss must be less than 1 ohm.
3. The maximum total length of intrinsically safe wiring extending from terminal S1 **shall not exceed 5,000 feet. (This excludes ground)**
4. The intrinsically safe terminals of the TA731XX can be connected to any non-energy storing switch device, such as a limit or float type switch or any Warrick electrode fitting assembly.
5. For additional guidance on "Hazardous Location Installation" and "Intrinsically Safe Devices", consult ANSI/ISA standard RP 12-6 or NEC articles 500 through 516.

### Installation

1. Mount the TA-731XX panel on wall or other solid object with 4 (four) #8 or appropriately sized screws.
2. Incoming Power: 3-wire 120 VAC supply, Class I circuit.

### **D-1 Installation Diagram**

(View with Lid Removed)

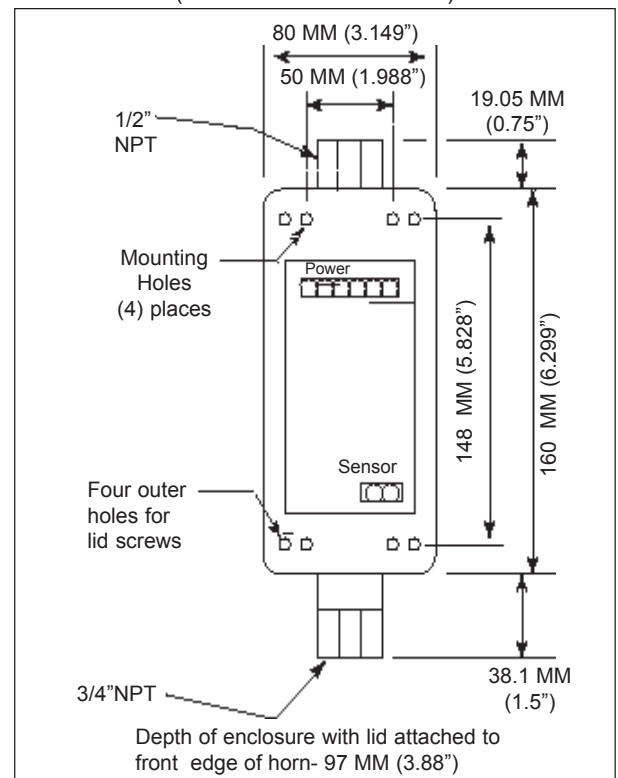

## D-2: Wiring Diagram

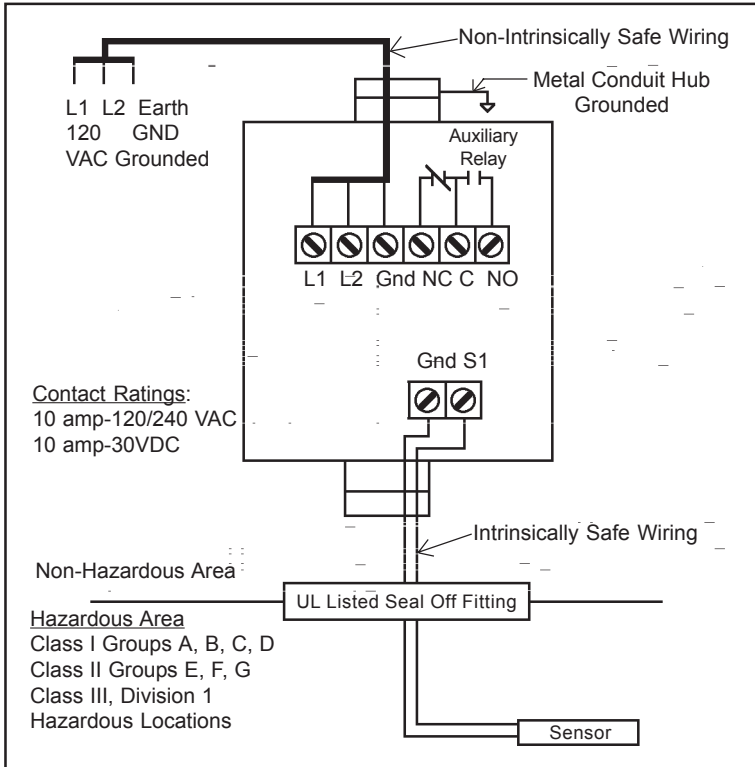

### Operation

**Dry Contact Operation:** The **green LED** will light when power is applied to the unit. When either sensor contact switches state (fault condition), the **horn** will activate and the appropriate **red and yellow LED's** will light. On pressing the **acknowledge** pushbutton, the **horn** will silence and the **yellow LED** will clear. The **red LED** will remain lit as long as the fault condition is present. On correcting the fault condition, the **red LED** will automatically clear.

During those situations when the fault condition occurs and corrects itself prior to pushing the **acknowledge** button, the **horn** and **red LED** will automatically activate and clear, matching the fault condition. However, the **yellow LED** will remain lit to indicate that the fault condition had previously taken place. Pressing the **acknowledge** button will clear the **yellow LED**.

### Test Button

Pushing the test button allows you to test the alarm panel circuitry. On pushing the **test** button, the **horn** will activate, the **red and yellow LED's** will light and the auxiliary relay will activate. On releasing the **test** button, the **horn**, **red LED** and auxiliary relay will deactivate. The **yellow LED** will remain lit until the **acknowledge** button is pressed.

### Model Number

TA 73 X X X

Optional Character  
0 - No option

Interface Contact (both same)  
A - N.O. dry contacts (close on fault)  
B - N.C. dry contacts (open on fault)

Number of Channels  
1 - One channel unit

Monitoring Panel

## D-3: Auxiliary Relay Slide Switch

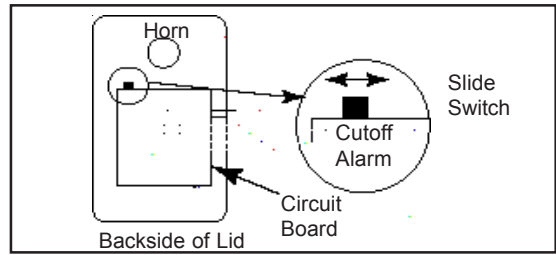

### Auxiliary Relay Operation

Model TA-731X0 contains an auxiliary relay for remote indication of a fault condition. The contact configuration shown in **Diagram D-2**, shows the position of the contacts in the non-fault condition. The relay can be field set to either a "cut-off" mode or "alarm" mode. In "cut-off" mode, only channel 1 will activate the auxiliary relay. The relay will mimic the **red LED** or fault condition. The relay will activate on fault condition, changing the state of the contacts. To deactivate the relay, you must clear the fault condition. Pressing the **acknowledge** button will not deactivate the relay. In "alarm" mode, the relay will mimic the horn. The relay will activate on fault condition changing the state of the contacts. To deactivate the relay, either press the **acknowledge** button or clear the fault condition. On models TA-731X1 and TA-732X2, the auxiliary relay is preset at the Factory and is not field adjustable.

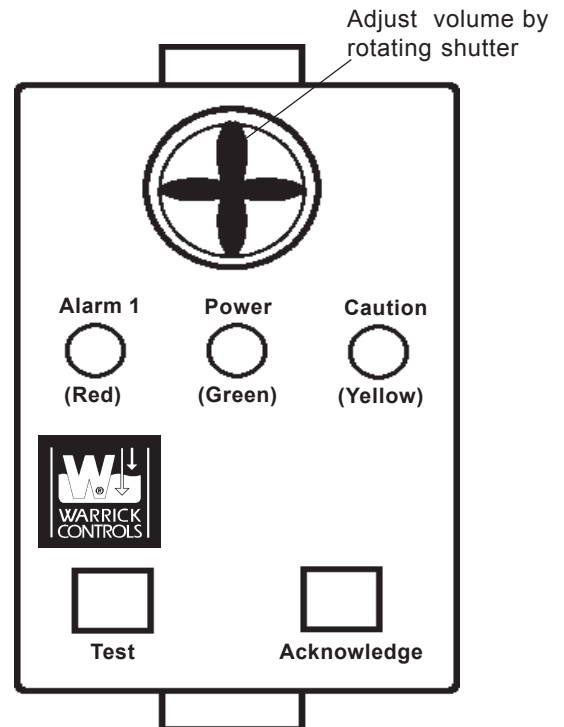

**Gems**  
Sensors

Gems Sensors Inc.  
One Cowles Road  
Plainville, CT 06062-1198  
Tel: 860-793-4579  
Fax: 860-793-4580