

## Warrick® Series 16M Controls Installation and Operation Bulletin

This bulletin should be used by experienced personnel as a guide to the installation of series 16M controls. Selection or installation of equipment should always be accompanied by competent technical assistance. We encourage you to contact Gems Sensors or its representative if further information is required.

### Specifications

**Control Design:** Solid state components enclosed in clear Lexan plug-in style housing. Housing carries no NEMA rating.

**Contact Design:** SPDT (1 form C): one normally open (N.O.) and one normally closed (N.C.), non-powered contacts.

**Contact Ratings:** 10A @ 120 or 240 VAC resistive, 1/3 H.P. @120 or 240 VAC.

**Contact Life:** Mechanical- 5 million operations. Electrical- 100,000 operations minimum at rated load.

**Supply Voltage:** 24, 120, or 240 VAC models- factory set. Plus 10%, minus 15%, 50/60 Hz.

**Supply Current:** 120, 240, 24 VAC, Relay energized 4.4 VA.

**Secondary Circuit:** 12 VAC RMS voltage on probes, 1.5 milli-amp current.

**Sensitivity:** Models operate from 0-1,000,000 OHM maximum specific resistance- factory set.

**Temperature:** -40 to 150° F. ambient.

**Terminals:** All connections #6-32 screw type with pressure clamps.

**Time Delays:** Standard, 0.5 seconds on rising level. Additional time delays on rising and/or falling available as option.

**Listings:** U.L. listed, Industrial Motor Control (508).

### Installation

1. Install octal socket in appropriate enclosure using two (2) #6 or #8 metal screws.
- 1A. Install rail mount socket on appropriate rail (DIN mount) in appropriate enclosure if applicable.
2. Wire control per wiring diagram, following N.E.C. and local codes
3. Install control module in socket.

### Sensitivities vs Maximum Probe Wire Distance\*

Sensitivity Character	Sensitivity (K Ohms)	Distance (Ft)
A or K	4.7	10,000
B or L	10	5,700
C or M	26	2,200
D or N	50	1,075
E or P	100	570
F or R	470	270
G or S	1,000	38

\* Based on type MTW or THHN wire, #14 or #16 Awg.

### Dimensional Diagram

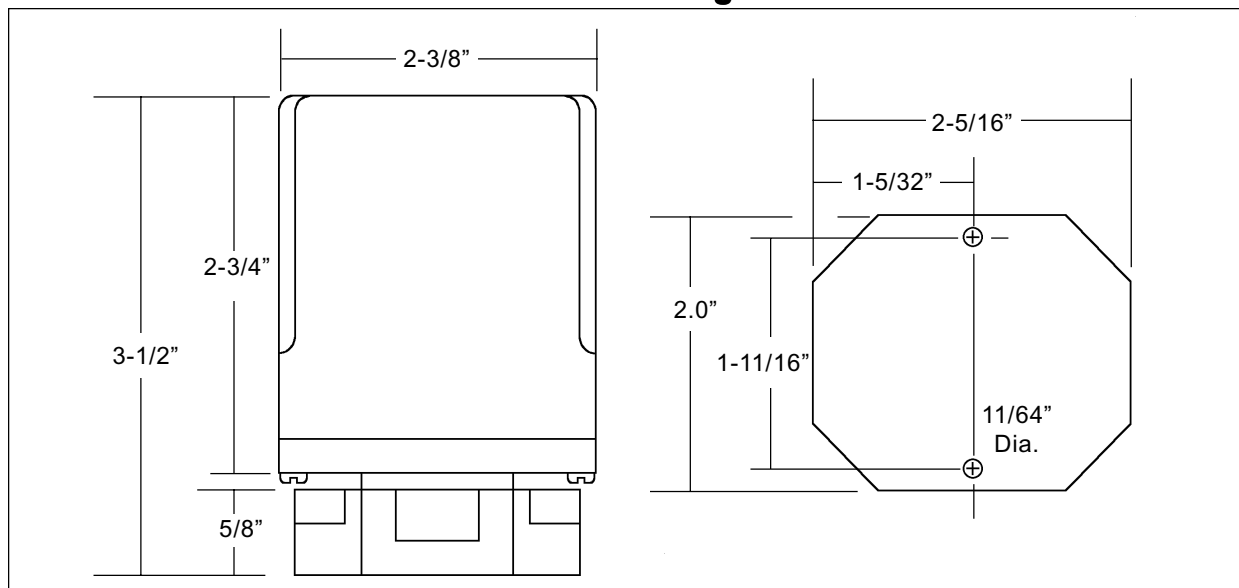

Use copper (60/70° C) wire only. Torque to 20 inch pounds.

## Operation

**Direct Mode- Single Level Service:** When the liquid rises to the electrode on terminal 3, the control energizes, changing state of the load contacts. (LED will be lit) The control remains energized until the liquid level recedes below electrode on terminal 3. The control then de-energizes, (LED will not be lit) returning load to original state.

**Inverse Mode- Single Level Service:** Control energizes with power, changing state of the load contacts. (LED will be lit) When the liquid rises to the electrode on terminal 3, the control de-energizes, returning the load contacts to shelf state. (LED will not be lit) The control remains de-energized until liquid level recedes below the electrode connected to terminal 3. The control then energizes.

**Direct Mode- Differential Service:** When the liquid rises to the electrode on terminal 3, the control energizes, changing state of the load contacts. (LED will be lit) The control remains energized until the liquid level recedes below electrode on terminal 4. The control then de-energizes, (LED will not be lit) returning the load contacts to original state.

**Inverse Mode- Differential Service:** Control energizes with power, (LED will be lit) changing state of the load contacts. When the liquid rises to the electrode on terminal 3, the control de-energizes, returning load contacts to shelf state. (LED will not be lit) The control remains de-energized until the liquid level recedes below the electrode on terminal 4. The control then energizes.

## Wiring Diagram

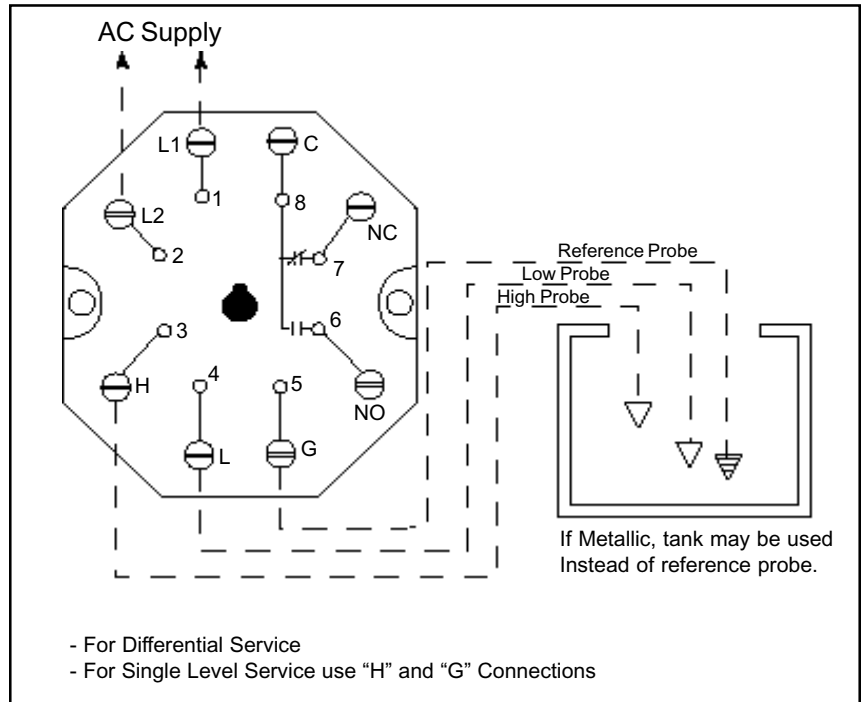

## Optional

**Time Delays:** With time delay on increasing level, the liquid must be in contact with the short electrode for the full duration of the time delay before control will operate. With delay on decreasing level, the liquid must be below long electrode for the full duration of the time delay before control will operate. In single level service, terminals 3 and 4 must be jumpered together to achieve time delays on both increasing and decreasing levels or just decreasing level.

**16M- X-X-X-X-XX-XX**

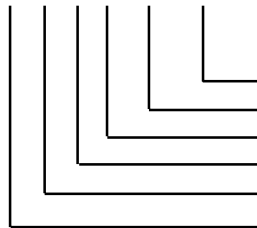

**Time Delay:** (decreasing level) 1-20 sec.

**Time Delay:** (increasing level) 1-20 sec.

**Enclosure:** 0- none, 1-NEMA 1, 4-NEMA 4, 7-NEMA 7, 12-NEMA 12

**Socket Style:** A- 8 Pin Octal, B- 8 Pin DIN mount, M- None, module only

**Supply Voltage:** 1- 120 VAC, 2- 240 VAC, 3- 24 VAC, 8- 208/240 VAC\*

**Mode/Sensitivity:**

**Direct** A- 4.7K, B- 10K, C- 26K, D- 50K, E- 100K, F- 470K, G- 1M

**Inverse** K- 4.7K, L- 10K, M- 26K, N- 50K, P- 100K, R- 470K, S- 1M

\*187 Vmin to 255 Vmax VAC



Gems Sensors Inc.  
One Cowles Road  
Plainville, CT 06062-1198  
Tel: 860-793-4579  
Fax: 860-793-4580